



European Committee for Standardization  
Comité Européen de Normalisation  
Europäisches Komitee für Normung

CEN/WS/BII2

## **BII11 - Qualification**

**PROFILE**

**DRAFT**

**Business Domain:** Pre award procurement

**Business Process:** Tendering – Awarding

**Document Identification:** CEN/WS/BII2/Profile BII11

**Version:** 2.0

**Release:** 2012-06-16

**Date of approval:**

## Document Summary

The Qualification profile describes a process providing electronic messaging support for identifying and verifying the capabilities of any Applicant that wants to present an offer to a particular contest (pre-awarding phase). It is for the business process of tendering in a pre-awarding phase. It is intended for use by businesses and purchasing authorities in restricted, negotiated, open or competitive dialogue procedures where access to participation is restricted to pre-qualified Applicants.

The key aspects covered by this profile are:

- An Applicant can use this profile to submit qualification documents to a Selector as specified in the Call for Tender documents.
- The profile can be used for pre-qualification as part of a restricted, negotiated or competitive dialogue tendering procedure or as qualification in an open procedure.
- The Qualification transaction is specific to a particular Call for Tender. It can be further refined in order to incorporate supporting documents such as a VCD document.
- The Selector evaluates the qualification information and reports his decision, positive or negative, to the Applicant. The decision reporting is out of the scope of this profile.
- In the case of a positive qualification response the Selector can continue with the tendering process. The positive qualification response may contain an invitation to submit a tender (not in this profile).

### Editors

- Oriol Bausà Peris
- Georg Birgisson
- Fred van Blommestein
- Arofan Gregory
- Anders Kingstedt

### Contributors

CEN/ISSS WS/BII2 e-Tendering Working group:

- Kornelis Drijfhout (chair), eTendering Team Lead/TenderNed, NL
- Ansgar Mondorf, University of Koblenz, DE
- Bas Crompvoets, TenderNed, NL
- Birgitta Nelson, SFTI/Kammarkollegiet, SE
- Chris Mora-Jensen, Inno:vasion, DK
- Daniel Reiser, University of Koblenz, DE
- Daniel Schmidt, University of Koblenz, DE
- Didier Hardy, OJEU, LU
- Eduardo Sanchez, Direccion General del Patrimonio del Estado, ES
- Frank-Dieter Dorloff, University of Duisburg-Essen, DE
- Giampaolo Sellitto, AVCP, IT
- Jostein Frømyr, Vice Chair Technical Coordination, NO
- Kerstin Wiss-Holmdahl, SFTI/SALAR, SE
- Magnus Matts, SFTI/Kammarkollegiet, SE
- Manuel Canno, Nexus-it, ES
- Marie Bodenhoff, Danish Regions, DK
- Nils Fjelkegård, eTendering Team Lead/Kammarkollegiet, SE

- Peter Dam Bové, SKI, DK
- Piero Milani, InfoCamere, IT
- Richard Baker, Sequence, UK
- Veit Jahns, University of Duisberg-Essen, DE
- Virpi Nieminen, PWC, BE

# Table of Contents

1	Introduction.....	5
1.1	CEN WS/BII2 profiles .....	5
1.2	CEN WS/BII2 Pre award support .....	5
1.3	Implementation, conformance and customization.....	6
2	Business environment .....	7
2.1	Introduction.....	7
2.2	Objectives.....	7
2.3	Scope .....	7
2.4	Tendering procedures .....	8
3	Requirements.....	9
3.1	Process requirements .....	9
3.2	Qualification information requirements.....	9
3.2.1	Qualification transaction business requirements .....	9
4	Profile detailed description .....	13
4.1	Business processes in scope .....	13
4.2	Roles involved .....	13
4.3	Qualification Business Process.....	14
4.4	Transaction Information requirements .....	15
4.4.1	Qualification Submission Transaction.....	15
4.4.2	Qualification Reception Confirmation.....	31
5	Implementation.....	35
6	References.....	36
6.1	General references relevant for all BII profiles.....	36
6.2	References specific to this profile.....	36

# 1 Introduction

This profile is a deliverable of the CEN ISSS BII2 workshop.

The original CEN Workshop on **Business Interoperability Interfaces for public procurement in Europe** (CEN ISSS BII) was concluded in December 2009, and its results, including a set of profiles, were issued as **CWA 16073:2010**. The objective of the second phase of the workshop – CEN WS/BII2 – was to provide a framework for interoperability in pan-European electronic procurement transactions, expressed as a set of requirements and technical specifications. The requirements are input into UN/CEFACT and the specifications are compatible with UN/CEFACT in order to ensure global interoperability.

Based on user input the CEN WS/BII2 has reviewed and updated a number of the profiles published as part of CWA 16073:2010. One of the updated profiles is profile BII22 that describes the Call for Tender process. This version 2 of BII22 – Call for tender is an updated version of the original BII22 profile. The update is not strictly upward compatible. See the BII document on Versioning and Change Management Policy for definition of upward compatibility in BII workshop documents.

## 1.1 CEN WS/BII2 profiles

A CEN WS/BII2 profile description is a technical specification describing

- the choreography of the business process covered, i.e. a detailed description of the way the business partners collaborate to play their respective roles and share responsibilities to achieve mutually agreed goals with the support of their respective information systems,
- the electronic business transactions exchanged as part of the business process, with their information requirements, and the sequence in which these transactions are exchanged,
- the business rules governing the execution of that business process, as well as any constraints on information elements used in the transaction data models

The profiles focus on the standardization on the organisational and semantics interoperability levels rather than on syntax or technical interoperability levels. Consequently the business transactions within a profile can be structured based on different message standards/syntax as long it can carry all the necessary information elements.

Although the profile descriptions and transaction data models provided by CEN WS/BII2 are neutral of syntax, the workshop also published specifications of how its data models may be mapped to defined syntaxes. This is done in order provide implementable specifications.

The main focus of the profile description and the associated transaction data models is to address generally expressed business requirements, applicable throughout the European market. Although the profile description is designed to meet generally expressed requirements, it is still the responsibility of the users to ensure that the actual business transactions exchanges meets all the legal, fiscal and commercial requirements relevant to their business.

## 1.2 CEN WS/BII2 Pre award support

The BII workshop has developed a set of profiles to support interoperability in the pre and post award areas. The scope of BII2 is public procurement but the profiles apply as well to private trade since many private customers use tendering as good business practice. In those cases official Notification of calls and contracts is often not applicable.

The scope of BII2 pre award profiles include processes that support communication of qualifications, calls for tender with and without catalogue templates, tenders with and without catalogues and contract notices. During these processes additional information need to be exchanged between awarding authorities and economic operators, such as questions and answers and documents supporting a final guarantee. These sub processes are currently out of scope for the workshop.

The set of BII profiles for supporting the pre award area are:

	<i>Profile</i>	<i>Process</i>	<i>Transactions</i>	<i>Version</i>
<b>BII11</b>	<b>Qualification</b>	<b>eTendering</b>	<b>Qualification Qualification Reception Notification</b>	<b>BII2</b>
BII12	Tendering Simple	eTendering	Tender Tender Reception Notification	BII2
BII22	Call for Tender	eTendering	Call for Tender	BII2
BII10	Tender Notification	eNotification	Publication Request Notice Publication Response Publication Correction Request Publication Confirmation	BII2
BII34	Call for Tender with Catalogue Template	eTendering	Call for Tender Pre-award Catalogue Template	BII2
BII35	Tendering Simple with Catalogue	eTendering	Tender Tender Reception Notification Pre-award catalogue	BII2

### 1.3 Implementation, conformance and customization

CEN WS/BII2 profiles define the core functionality that is required in order to achieve interoperability for the business processes that are covered. Parties, claiming conformance to a CEN WS/BII2 profile must be capable of:

- Processing all non-optional transactions that are defined in the profile
- Sending all mandatory elements within the transactions
- Processing all elements within the transactions they receive

Parties may agree bilaterally or within certain communities to extend the core set of information elements, or to adapt their cardinality. This extension mechanism is described in the BII Technical Guideline: BII conformance and customization, which is annexed to CEN CWxxxx0.

In order to implement a profile, the transactions are to be represented in some syntax. Syntax representation is outside the scope of the profiles; however, the mapping of the profile transactions to UBL 2.0 and to UN/CEFACT has been described. In the profiles, reference is made to technical documents such as XML schemas, Schematron files and example messages to support technical implementation.

Implementations of the profiles may be validated by means of tools and supporting material, as described in the BII Technical Guideline: BII implementation and use of validation artefacts, annexed to CEN CWxxxx0. More background information and support material can be found on the CEN WS/BII2 website <http://www.cenbii.eu/>.

---

## 2 Business environment

### 2.1 Introduction

Individual pre-awarding processes can be followed using different procedures. The qualification process in Open procedures is part of the tender submission. Restricted, negotiated and competitive dialogue procedures require pre-qualification of the candidates before inviting them to participate in the tendering process.

### 2.2 Objectives

The main business benefits to be gained by implementing this profile are:

1. The profile is a basis for an EDI agreement between the parties and enables trading partners to communicate without a previous bi-lateral setup or agreements.
2. The electronic qualification allows the Selector to install a systematic qualification process.
3. Applicants can automatically generate participation requests issuing qualification documents.
4. Receipt of qualification information allows for automated qualification process.

### 2.3 Scope

This profile supports a process of qualification by submitting a virtual company dossier. It is intended to support transmission of electronic documents for processing in semi automated processes by the receiver. The legal requirements that were taken into account are requirements from European legislation, in particular the EU directives, mentioned in section 6 of this profile. The intended scope for this profile includes Business to Business (B2B) and Business to Government (B2G) relations, with a focus on B2G.

The transactions, specified in this profile are intended to be exchanged between the tendering systems of economic operators and contracting authorities. This means that it is expected that the parties have connected their systems to the internet, and that they have middleware in place to enable them to send and receive the transactions in a secure way, using an agreed syntax.

The content model of the transactions can also be used in procurement platforms or portals, so that these platforms as well as procurement systems of Economic Operators and Contracting Authority are based on the same information and process models, which makes them more interoperable. Even if platforms are not technically interoperable, the content model facilitates understanding the tendering documents and to participate in the tendering process.

## 2.4 Tendering procedures

Article 28 to 34 from Directive 2004/18/EC and article 40 from Directive 2004/17/EC describe the different tendering procedures used by Contracting Authorities. By focusing on the exchange of information steps three abstract process models remain: Open procedure, Restricted procedure and Award of a contract without a prior publication of a contract notice.

### **The Open procedure**

This procedure starts with the publication of a Contract notice. Economic operators have access to the notice and the contract documents. The contract authority provides the Call-For-Tender to all interested economic operators. After preparing the tenders, all economic operators submit their qualification and tender documents. The contracting authority evaluates all tenders and awards the contract to the winning economic operator. The procedure ends by the publication of the Award of a contract.

### **The Restricted procedure**

This procedure starts with the publication of a Contract notice. Economic operators have access to the notice and the contract documents. The contract authority provides the Call-For-Tender to all interested economic operators. Based on the Call-For-Tender all economic operators submit their qualification documents first. The contracting authority evaluates the economic operators and invites only the selected ones to submit their tender. After preparing the tenders, the invited economic operators submit their tender documents. The contracting authority evaluates all tenders and awards the contract to the winning economic operator. The procedure ends by the publication of the Award of a contract.

This process covers the procedures Competitive dialog and Negotiated procedure with a call for competition as well. The actual dialog or negotiation will most likely not be standardized and is therefore not in scope of this model.

### **Award of a contract without a prior publication of a contract notice**

This procedure starts with the invitation to selected economic operators to submit their tenders. The contract authority provides the Call-For-Tender to these economic operators. After preparing the tenders, the invited economic operators submit their qualification and tender documents. The contracting authority evaluates all tenders and awards the contract to the winning economic operator. To provide maximum transparency the contracting authority may publish the Voluntary ex ante transparency notice two weeks before the actual Award of a contract.

This process covers the Negotiated procedure without a call for competition as well. The actual negotiation will most likely not be standardized and is therefore not in scope of this model.

### **e-Notification**

Official notification through publishing bodies is part of all procedures. The process of eNotification is described in a separate BII profile document: BII10: Tender Notification.



## 3 Requirements

### 3.1 Process requirements

The Applicant evaluates the Call for Tender information and prepares a Qualification documents to apply for participation. The Applicant sends the Qualification document to the Selector. The Selector evaluates the Qualification document and may report the results to the Applicant. A positive response may include an invitation to tender.

The Qualification may be further refined in order to incorporate supporting documents such as a VCD document. The process of qualification may be extended to include guaranties from a guarantor to the Selector. This extended process is not in scope and is not further elaborated on in this profile.

### 3.2 Qualification information requirements

#### 3.2.1 Qualification transaction business requirements

##### *General requirements*

ID	Requirement
tbr41-001	The economic operator must be able to include all information necessary for identification: Name, Party Identification, Endpoint ID.
tbr41-002	The economic operator should be able to include contact information: Postal address, telephone number, fax number, e-Mail address, contact person(s).
tbr41-003	The economic operator must be able to define his country of registration. The country of registration is needed to identify relevant evidences and the legal domain of evidence provision.
tbr41-004	For each economic operator, its role (main contractor, additional contractor, sub-contractor) must be included. The tenderer structure may consist of a single economic operator, each maybe having sub-contractors, which in turn may have further sub-contractors and so on. The main contractor or authorised representative takes a specific role and must therefore proof additional criteria that are not relevant for other contractors or sub-contractors. The tenderer structure may also consist of several economic operators (one main contractor and additional contractors) forming a bidding consortium/joint venture. Each economic operator/contractor must proof specific criteria defined in the call for tender. The structure of bidding consortia must be specified when several companies associate to tender together. In this case there must be a tenderer structure to include all the information concerning all the requirements for all the members that form the consortium. It is generally important to distinguish between main contractor, additional contractors and sub-contractors.
tbr41-005	The qualification document must contain the link between each sub-contractor and the economic operator which sub contracts him. Sub-contractors have to be assigned to contractors as they may proof certain technical and financial capabilities of a contractor. Sub-contractors do not need to proof all criteria that are relevant for contractors.

##### *Natural Person*

ID	Requirement
tbr41-006	The economic operator should be able to name a natural person and to include all the personal information necessary for identifying this natural person (e.g. Identifier, name, nationality, address, place of birth, date of birth). The natural person takes a specific role in the company in the qualification phase. Natural persons have to proof suitability with certain criteria if they have a particular role in the company (e.g. authorized representative).
tbr41-007	The economic operator should be able to describe the role of the natural person within the company. The role clarifies the relevance of the natural person for the tender (e.g.

ID	Requirement
	CEO, technical director) and whether evidence need to be provided. The role is in particular relevant if specific qualification or power of attorney has to be evidenced.
tbr41-008	If there is a person having the power of attorney, i.e. legal support to sign contracts for the company, this person needs to be stated specifically. This requirement is specifically important and relevant for the signature of the qualification document and its verification.
tbr41-009	The economic operator must be able to include the country in which the natural person is registered. The country of registration is needed to identify relevant evidences and the legal domain of evidence provision. The country of registration is in particular relevant when it is different to the nationality of the person in order to let economic operators and contracting authorities identify/verify evidences provided for the natural person.

#### *Contracting authority*

ID	Requirement
tbr41-010	The contracting authority must be identified, hence information about the party are required, such as party name, identification, endpoint id.
tbr41-011	The qualification document should contain contact information of the contracting authority: Postal address, telephone number, fax number, eMail address, contact person(s).

#### *Call for tender*

ID	Requirement
tbr41-012	The document must contain a reference to the call for tender, i.e. URL to the notification platform and the call for tender ID, which defines the requirements (i.e. criteria) for which this document is created and submitted by the economic operator. It should be possible to maintain this information in order to keep track of the connection between request (call for tender) and response (this qualification document).
tbr41-013	The qualification document must contain information about the legal domain of the call for tender that states under which legislation it is carried out. It is important to know (for systems, humans) to perform the criteria-evidence-mapping. Especially in cross-border procurement it is necessary to know the legal domain under which legislation the contract will be carried out to identify suitable evidences to be provided for the given criteria.
tbr41-014	The economic operator may be able to reuse as much information from the call for tender as possible when elaborating the qualification document. It may be possible to define the criteria information (among other things) in the call for tender in a structured way that can be imported into the qualification document. This requirement very much relies on the alignment of Call For Tender and Qualification data models.

#### *Procurement lots*

ID	Requirement
tbr41-015	The document may contain information about the procurement lots defined in a call for tender and define for each economic operator, which lot he is applying to. If the contract described in the call for tender is divided into different lots, the economic operator should be possible to state for which specific lot he is applying.

#### *Criteria of qualitative selection*

ID	Requirement
tbr41-016	The qualification document must contain information for each criterion to describe it more detailed, i.e. providing the legal "semantics". The criteria should be described using information such as: Legal reference (EU level, contracting authority national

ID	Requirement
	level, economic operator national level), type of criterion (e.g. technical capability, financial standing, etc.), criterion group to which it belongs (according to names of Art. 45-50 of 2004/18/EC). This information is provided by the user, who includes the information from the call for tender or it is automatically/directly imported from the call for tender (cf. TrRq41-012).
tbr41-017	The qualification document must contain information about the criteria that are specifically assigned to an economic operator as a legal entity. 2004/18/EU Art. 45-50. Criteria that refer to an economic operator must clearly relate to the economic operator, e.g. by a reference to the corresponding criteria definition within the section where the economic operator is defined.
tbr41-018	The qualification document must contain information about the criteria that are specifically assigned to a natural person (e.g. the authorized representative). 2004/18/EU Art. 45-50. Criteria that refer to natural persons must clearly relate to the natural person, e.g. by a reference to the corresponding criteria definition. Natural persons have to proof suitability with certain criteria if they have a particular role in the company (e.g. authorized representative).
tbr41-019	The qualification document may contain information about the regulation level of each criterion specifying the legal reference to European regulation, to the regulation of the economic operator's nationality/legal domain and to the contracting authority's nationality/legal domain. This is the fundamental requirement for cross-border tendering. This information is used for the criteria-evidence-mapping between different national procurement regulations.

*Additional documentation*

ID	Requirement
tbr41-020	The economic operator should be able to supplement and clarify the certificates and documents submitted, when requested in the call for tender, i.e. he needs to be able to include any additional documents that are not classified as evidences that prove specific criteria. 2004/18/EU Art. 51

*Approved economic operators*

ID	Requirement
tbr41-021	The economic operator should be able to include information about enrolment in an official list of approved economic operators indicating the classification in this list for the suitability to do certain works or provide certain services. Art. 52 2004/18/EU. In case a pre-qualification already certifies that an economic operator fulfils a certain criterion, this should be stated in the qualification document by an official certification of enrolment in such a list. In such cases, the economic operators do not need to provide and attach evidences.

*Evidences*

ID	Requirement
tbr41-022	The economic operator must be able to attach evidence documents and certificates which prove his compliance to the requested criteria defined in the call for tender. These evidence documents or additional information allow the contracting authority to evaluate the compliance of the economic operator to the criteria of qualitative selection defined in the call for tender.
tbr41-023	The qualification document must reflect the connection between a criterion and the evidence that has been attached to prove compliance to it and vice versa, i.e. it has to contain cross-references between criteria and evidences. One evidence may prove fulfilment of several legal or specific requirements (i.e. the criteria) established in the call for tenders.
tbr41-024	The qualification document may contain a reference to the requirements in the call for tender for every evidence document contained in the qualification document. All the

ID	Requirement
	requirements for tenderers specified in the call for tender should be answered in the qualification documents. Therefore it would be very useful to keep a reference to these requirements in the documents provided by the tenderer.

*Evaluation of criteria*

ID	Requirement
tbr41-025	The qualification document may contain structured information describing the content of included evidence. This is essential for automatic evaluation of criteria and provided evidences. This structured information should reflect information about what the given evidence proves with respect to the requested requirements expressed in the criteria.

*Issuing date and time*

ID	Requirement
tbr41-026	The qualification document should reflect the date and time when the qualification document has been issued.

*Versioning*

ID	Requirement
tbr41-027	The qualification document should allow to include a VersionID to the Qualification Document. The VersionID helps to identify the status of subsystems that have supported the creation of a Qualification Document. It is needed to trace changes that have occurred.

*Issuing body*

ID	Requirement
tbr41-028	The qualification document may reflect information about the issuing body of the qualification document itself.
tbr41-029	The qualification document may reflect information about the issuing body of the evidences or additional documents.

*Digital signature*

ID	Requirement
tbr41-030	The qualification document shall be capable of being signed and containing the signature information for later verification. All information required to validate the digital signature need to be included, such as signature method, signature certificate, etc.
tbr41-031	For every economic operator, in case the document is signed, it should be possible to verify the power of attorney of the signers of the document. If the document is signed, then this is done by an authorized representative of the company, in this case having the power of attorney. The signature certificate of that person needs to be included in order to verify the signature.
tbr41-032	The qualification document shall contain information about the validation / verification of signatures of a (signed) document that has been attached to it. If the qualification document / VCD contains signed documents, it should be possible in these cases to include information about the result of verification of the signatures in case they are already validated during creation time of the qualification document, i.e. the time when a signed document is included into the qualification document.

## 4 Profile detailed description

### 4.1 Business processes in scope

Procurement is a complex domain with several key processes, some of which are illustrated in the following figure.

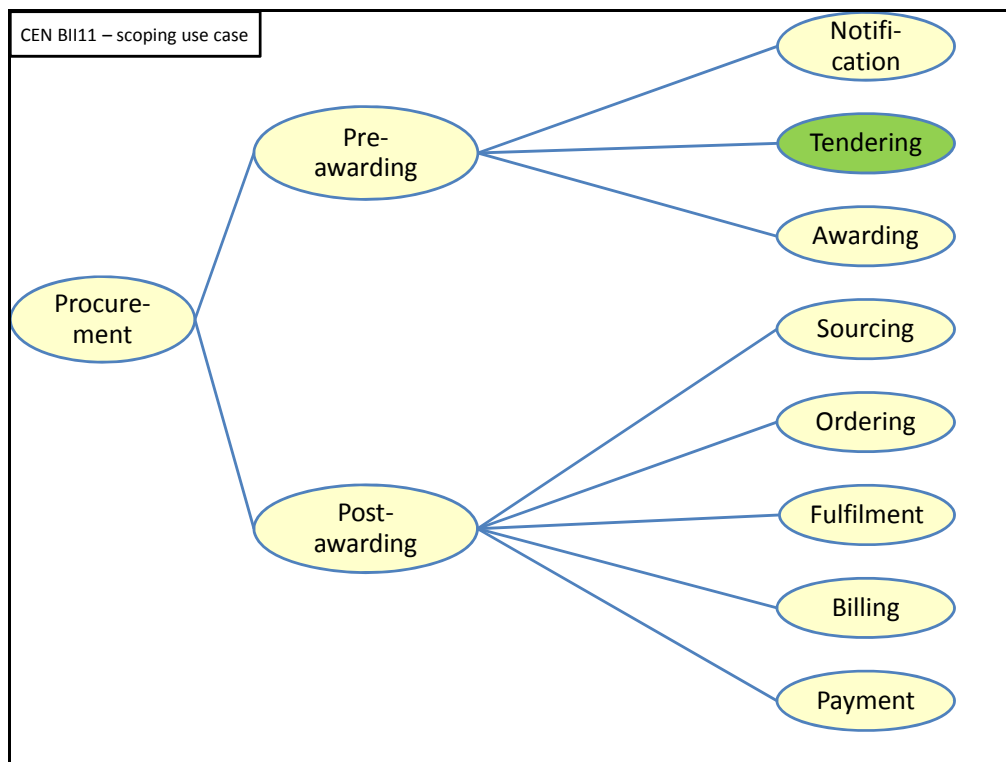

The Qualification profile is part of the Tendering process, as highlighted in the above figure.

### 4.2 Roles involved

The following business partners participate in this profile, acting in the roles as defined below.

Business partner	Description
Customer	The customer is the legal person or organization who is in demand of a product or service.  Examples of customer roles: buyer, consignee, debtor, contracting authority.
Supplier	The supplier is the legal person or organization who provides a product or service.  Examples of supplier roles: seller, consignor, creditor, economic operator.

Role/actor	Description
Selector	A party who evaluates submitted qualification information.
Applicant	A party who submits qualification information with the intention of participating in a tender

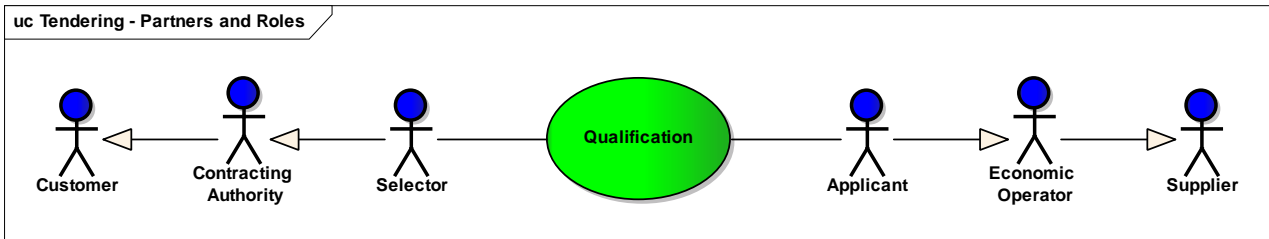

### 4.3 Qualification Business Process

The following diagram shows the choreography of the business process implemented by the profile. The choreography of business collaborations defines the sequence of interactions when the profile is run within its context.

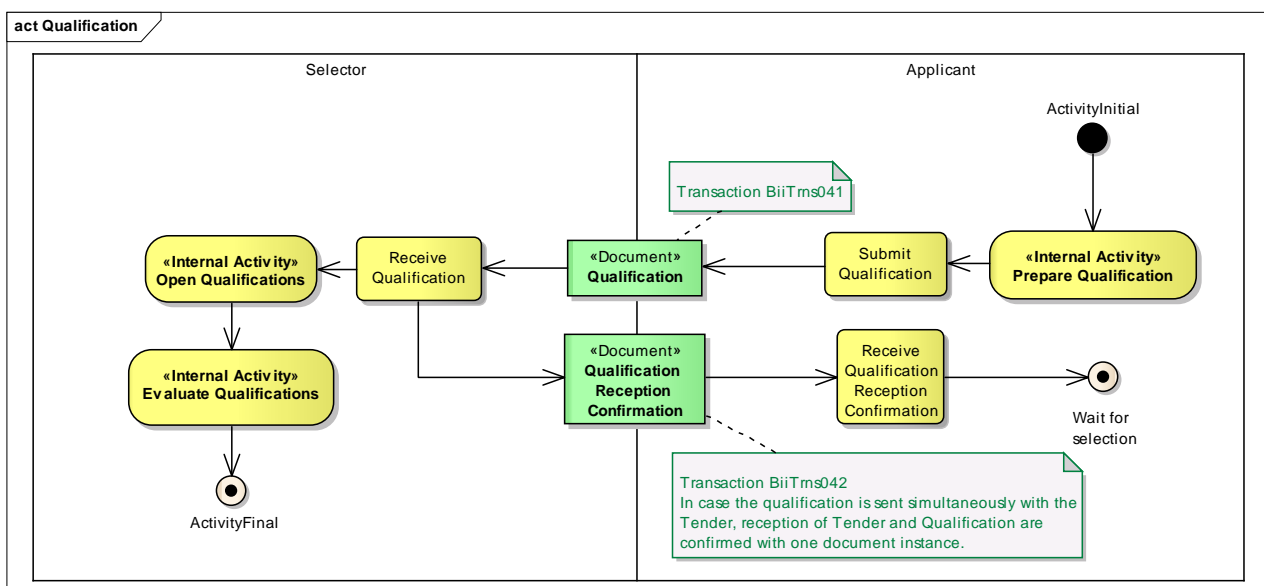

Categories	Description and Values
Description	<p>The Applicant sends an electronic Qualification document containing the information requested by the Selector in the Call for Tender for qualification.</p> <p>The reception of the Qualification is confirmed by the Selector.</p> <p>The Selector evaluates the qualification information. The evaluation process can be supported by business information held by trusted third parties acquired through external processes.</p> <p>The results of the qualification are reported to the Applicant. A positive result may include an invitation to tender.</p>
Pre-conditions	A Contracting Authority as a selector has issued a call for tender to potential Applicants, including a call for qualification.
Post-conditions	Qualifications have been received by the Selector and are to be evaluated by him. Rejected Applicants will be informed, accepted Applicants are to receive an invitation to tender.
Scenarios	<p>Qualification accepted.</p> <p>External information required.</p> <p>Qualification rejected.</p>

Categories	Description and Values
Remarks	The qualification process may require guaranties. These quarantines may be included as attachment documents to the qualification but are not specifically shown in this profile since the guarantee process itself is out of scope of this profile and is not elaborated on further in this document.

## 4.4 Transaction Information requirements

### 4.4.1 Qualification Submission Transaction

Categories	Description and Values
Identifier	BiiTrns041
Description	A structured electronic business document for providing information requested by a Contracting Authority in a Call for Tender.
Partner Types	Customer Supplier
Authorized Roles	Applicant Selector
Legal Implications	By submitting a Qualification document the Economic Operator as Applicant is legally responsible for the correctness of the information provides.
Initial Event	Economic Operator as Applicant prepares and sends Qualification document
Terminal event	Contracting Authority as Selector processes the Qualification document.
Scope	All tendering procedures in public or private sector.
Boundary	None specified.

### 4.4.1.1 Qualification Submission Transaction Information Requirements Model

#### Overview





*Information Requirements Model*

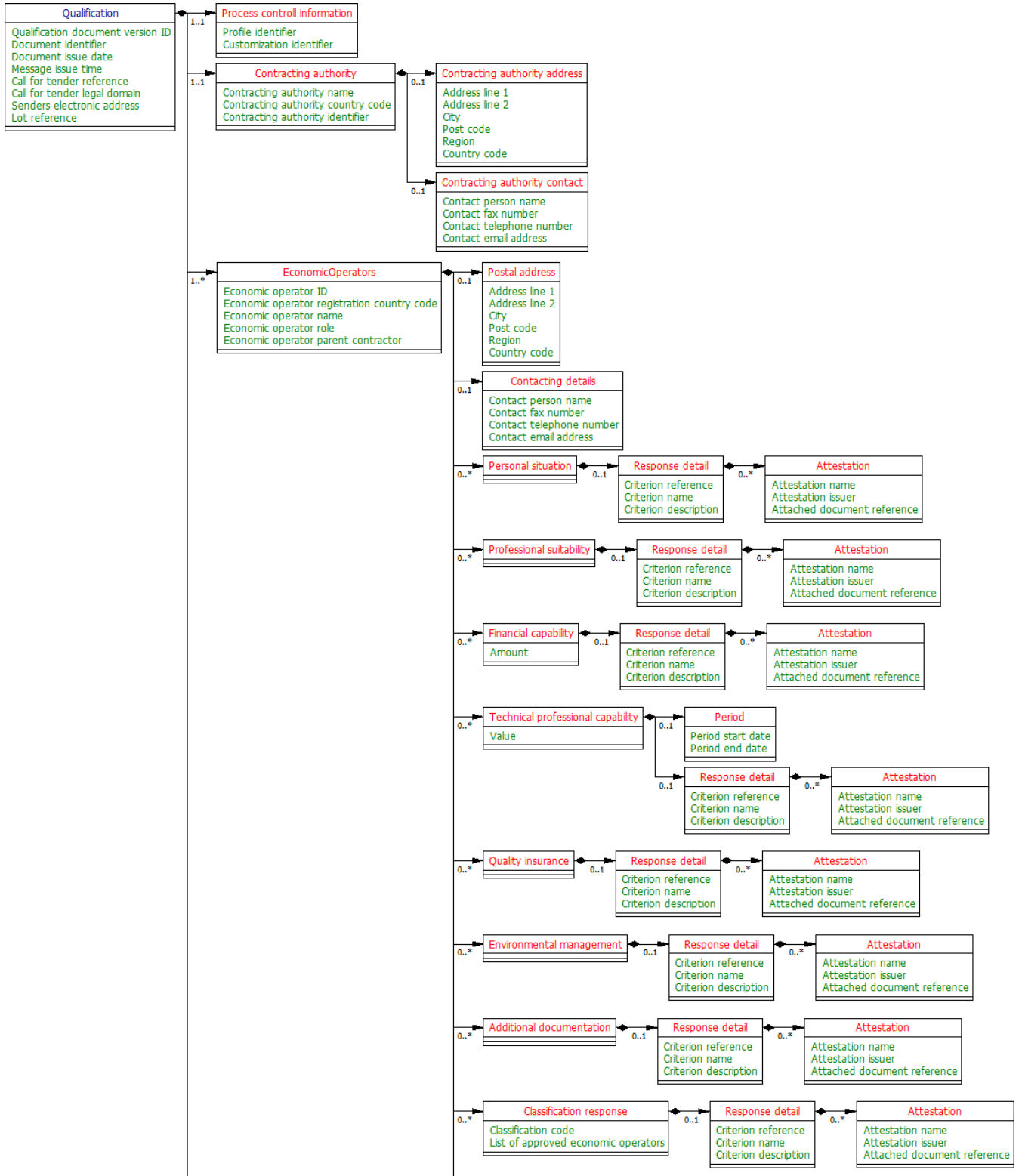

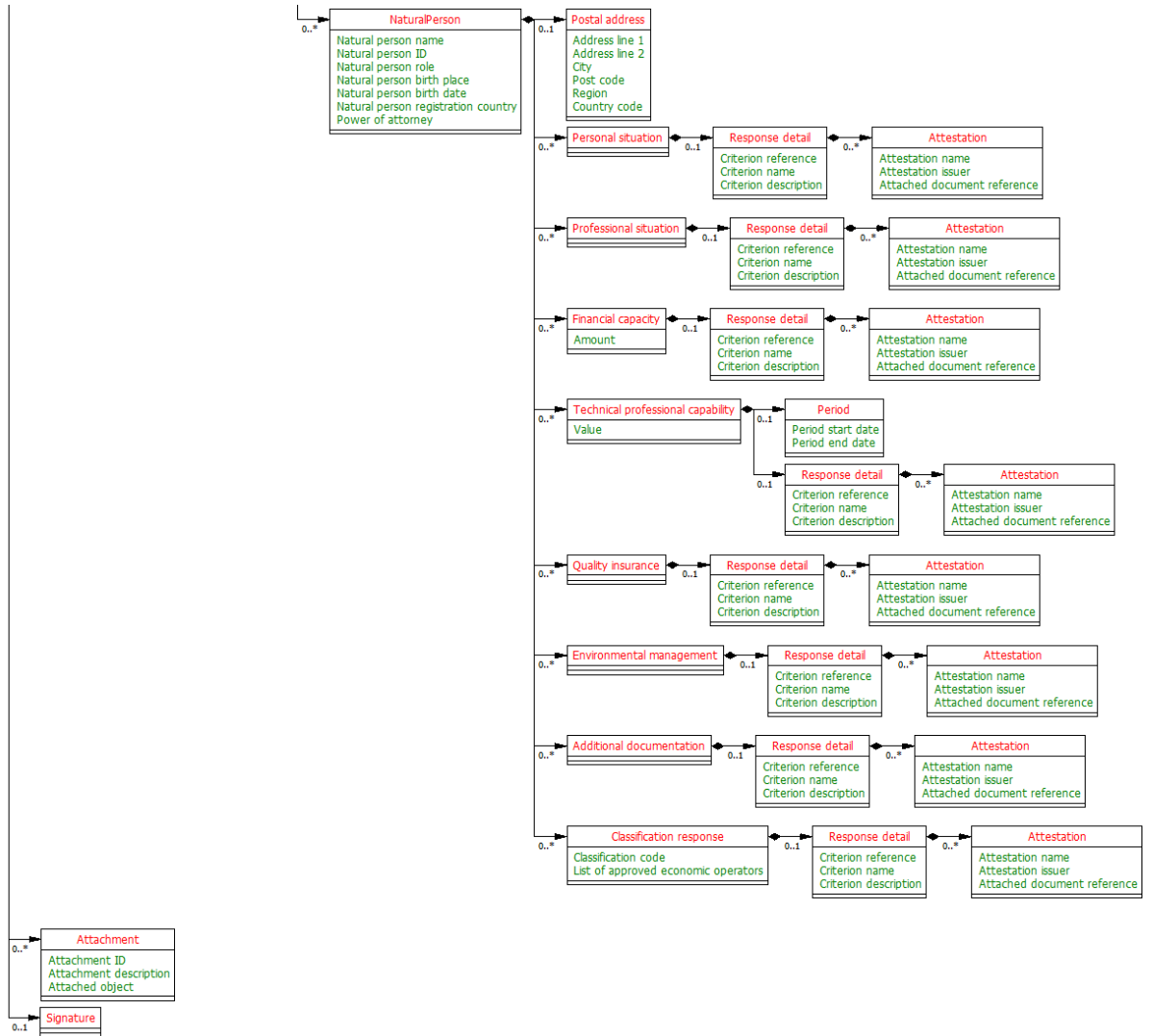

#### 4.4.1.2 Qualification Submission Transaction Information Requirements

InfRqID	Crd	Tree and Business term	Usage	Data Type	ReqID	Note
		Qualification				
tir41-001	0..1	Qualification document version ID	Identifies the version of the document	BiiDT::Undefined		
tir41-022	1..1	Document identifier	An transaction instance must contain an identifier. The identifier enables positive referencing the document instance for various purposes including referencing between transactions that are part of the same process.	BiiDT::Undefined		
tir41-002	1..1	Document issue date	The date on which the transaction instance was issued.	BiiDT::Date		
tir41-003	1..1	Message issue time	The date with timestamp the document has been issued	BiiDT::Time		
tir41-005	0..1	Call for tender reference	A reference to the Call for Tender to which this Qualification document is delivered as a response.	BiiDT::Text		
tir41-006	0..1	Call for tender legal domain	The legal domain by which the contract is covered. The legal domain refers to a specific law or procurement regulation of a certain country.	BiiDT::Text		
tir41-004	0..1	Senders electronic address	The electronic address (end point) from where this qualification document is transmitted. Identifies the issuer of the document	BiiDT::Text		
tir41-007	0..n	Lot reference	A reference to one or more lots the economic operator is applying for. The original lot definition is part of the call for tender document. The Qualification instance only references the corresponding IDs in order to establish the connection to the call for tender information.	BiiDT::Text		
	1..1	Process controll information	Information about the specification that apply to the transaction.	CENBII common structures::Process control		
tir41-024	1..1	Profile identifier	Identifies the BII profile or business process context in which the transaction appears.	BiiDT::Code	tbr00-001	
tir41-025	1..1	Customization identifier	Identifies the specification of content and rules that apply to the transaction.	BiiDT::Code	tbr00-002 BusRqYY	
	1..1	Contracting authority	Information about the contracting authority that is awarding the contract and has sent out the call for tender. The contracting authority is usually the final receiver of a Qualification instance.	Main::Contracting authority		
tir41-026	0..1	Contracting authority name	The name of the contracting authority.	BiiDT::Text		
tir41-027	0..1	Contracting authority country code	Code identifying the country in which the contracting authority is located.	BiiDT::Code		
tir41-028	0..1	Contracting authority identifier	An identifier of the contracting authority	BiiDT::Undefined		
	0..1	Contracting authority address	Address information.	CENBII common structures::Postal address		
tir41-029	0..1	Address line 1	The main address line in a postal address usually the street name and number.	BiiDT::Undefined		
tir41-030	0..1	Address line 2	An additional address line in a postal address that can be used to give further details supplementing the main line. Common use are secondary house number in a complex or in a building.	BiiDT::Undefined		

InfRqID	Crđ	Tree and Business term	Usage	Data Type	ReqID	Note
tir41-031	0..1	City	The common name of the city where the postal address is. The name is written in full rather than as a code.	BiiDT::Undefined		
tir41-032	0..1	Post code	The identifier for an addressable group of properties according to the relevant national postal service, such as a ZIP code or Post Code.	BiiDT::Undefined		
tir41-033	0..1	Region	For specifying a region, county, state, province etc. within a country by using text.	BiiDT::Undefined		
tir41-034	0..1	Country code	The country where the address is. The country should always be given by using ISO code 3166 alpha 2	BiiDT::Code		
	0..1	Contracting authority contact	Used to provide contacting information for a party in general or a person.	CENBII common structures::Contacting details		
tir41-035	0..1	Contact person name	The name of the contact person.	BiiDT::Text		
tir41-036	0..1	Contact fax number	A fax number for the contact persons.	BiiDT::Undefined		
tir41-037	0..1	Contact telephone number	A phone number for the contact person. If the person has a direct number, this is that number.	BiiDT::Undefined		
tir41-038	0..1	Contact email address	The e-mail address for the contact person. If the person has a direct e-mail this is that email.	BiiDT::Undefined		
	1..n	EconomicOperators	Information about the economic operator submitting the qualification. Identifies the economic operator submitting the Qualification.	Main::Economic operators		
tir41-039	0..1	Economic operator ID	An identifier that conclusively identifies the economic operator, such as a legal registration identifier.	BiiDT::Identifier		
tir41-010	0..1	Economic operator registration country code	The registration country code of th economic operator submitting the qualification.	BiiDT::Code		
tir41-011	1..1	Economic operator name	The name of the economic operator submitting the Qualification.	BiiDT::Text		
tir41-040	0..1	Economic operator role	The role in a consortium that the economic operator has while submitting the qualification (main contractor, subcontractor , additional)	BiiDT::Code		
tir41-023	0..1	Economic operator parent contractor	Reference to the economic operator that subcontracts this economic operator, e.g. the Economic operator ID.	BiiDT::Undefined		
	0..1	Postal address	Address information.	CENBII common structures::Postal address		
tir41-041	0..1	Address line 1	The main address line in a postal address usually the street name and number.	BiiDT::Undefined		
tir41-042	0..1	Address line 2	An additional address line in a postal address that can be used to give further details supplementing the main line. Common use are secondary house number in a complex or in a building.	BiiDT::Undefined		
tir41-043	0..1	City	The common name of the city where the postal address is. The name is written in full rather than as a code.	BiiDT::Undefined		
tir41-044	0..1	Post code	The identifier for an addressable group of properties according to the relevant national postal service, such as a ZIP code or Post Code.	BiiDT::Undefined		

InfRqID	Crd	Tree and Business term	Usage	Data Type	ReqID	Note
tir41-045	0..1	Region	For specifying a region, county, state, province etc. within a country by using text.	BiiDT::Undefined		
tir41-046	0..1	Country code	The country where the address is. The country should always be given by using ISO code 3166 alpha 2	BiiDT::Code		
	0..1	Contacting details	Used to provide contacting information for a party in general or a person.	CENBII common structures::Contacting details		
tir41-047	0..1	Contact person name	The name of the contact person.	BiiDT::Text		
tir41-048	0..1	Contact fax number	A fax number for the contact persons.	BiiDT::Undefined		
tir41-049	0..1	Contact telephone number	A phone number for the contact person. If the person has a direct number, this is that number.	BiiDT::Undefined		
tir41-050	0..1	Contact email address	The e-mail address for the contact person. If the person has a direct e-mail this is that email.	BiiDT::Undefined		
	0..n	Personal situation	Structured information about the exclusion criteria for tenderers who are allowed to participate in the tender process, which may be used for automatic evaluation of the administrative qualification documents submitted by the tenderers. These exclusion criteria regard the requirements mentioned in article 45 of the Directive 2004/18/EC	Main::Personal situation		
	0..1	Response detail	Further details of the response in a structured form.	Main::Response details		
tir41-051	0..1	Criterion reference	A reference to the criterion that being responded to e.g. the as stated in the Call for tender.	BiiDT::Text		
tir41-052	1..1	Criterion name	The name of the criterion that is being responded to.	BiiDT::Text		
tir41-053	1..1	Criterion description	A description of the criterion that is being responded to	BiiDT::Text		
	0..n	Attestation		Main::Attestation		
tir41-054	0..1	Attestation name	The name of the attestation that proves the qualification.	BiiDT::Text		
tir41-068	0..n	Attestation issuer	The attestation that proves the qualification	BiiDT::Undefined		
tir41-069	0..n	Attached document reference	An internal document reference to an attached document that supports this attestation.	BiiDT::Undefined		
	0..n	Professional suitability	Structured information about the selection criteria for tenderers who are allowed to participate in the tender process, which may be used for automatic evaluation of the administrative qualification documents submitted by the tenderers. These selection criteria regard the requirements mentioned in article 46 of the Directive 2004/18/EC	Main::Professional situation		
	0..1	Response detail	Further details of the response in a structured form.	Main::Response details		
tir41-070	0..1	Criterion reference	A reference to the criterion that being responded to e.g. the as stated in the Call for tender.	BiiDT::Text		
tir41-071	1..1	Criterion name	The name of the criterion that is being responded to.	BiiDT::Text		
tir41-072	1..1	Criterion description	A description of the criterion that is being responded to	BiiDT::Text		

InfRqID	Crds	Tree and Business term	Usage	Data Type	ReqID	Note
	0..n	Attestation		Main::Attestation		
tir41-073	0..1	Attestation name	The name of the attestation that proves the qualification.	BiiDT::Text		
tir41-074	0..n	Attestation issuer	The attestation that proves the qualification	BiiDT::Undefined		
tir41-075	0..n	Attached document reference	An internal document reference to an attached document that supports this attestation.	BiiDT::Undefined		
	0..n	Financial capability		Main::Financial capacity		
tir41-076	0..1	Amount		BiiDT::Amount		
	0..1	Response detail	Further details of the response in a structured form.	Main::Response details		
tir41-077	0..1	Criterion reference	A reference to the criterion that being responded to e.g. the as stated in the Call for tender.	BiiDT::Text		
tir41-078	1..1	Criterion name	The name of the criterion that is being responded to.	BiiDT::Text		
tir41-079	1..1	Criterion description	A description of the criterion that is being responded to	BiiDT::Text		
	0..n	Attestation		Main::Attestation		
tir41-080	0..1	Attestation name	The name of the attestation that proves the qualification.	BiiDT::Text		
tir41-081	0..n	Attestation issuer	The attestation that proves the qualification	BiiDT::Undefined		
tir41-082	0..n	Attached document reference	An internal document reference to an attached document that supports this attestation.	BiiDT::Undefined		
	0..n	Technical professional capability		Main::Technical capability		
tir41-083	0..1	Value	The value that complies with the criterion.	BiiDT::Numeric		
	0..1	Period	Dates that describe a period that has relevance in the context of the transaction.	CENBII common structures::Date periods		
tir41-084	1..1	Period start date	The date on which the period starts. The start dates counts as part of the period.	BiiDT::Date		
tir41-085	1..1	Period end date	The date on which the period ends. The end date counts as part of the period.	BiiDT::Date		
	0..1	Response detail	Further details of the response in a structured form.	Main::Response details		
tir41-086	0..1	Criterion reference	A reference to the criterion that being responded to e.g. the as stated in the Call for tender.	BiiDT::Text		
tir41-087	1..1	Criterion name	The name of the criterion that is being responded to.	BiiDT::Text		

InfRqID	Crds	Tree and Business term	Usage	Data Type	ReqID	Note
tir41-088	1..1	Criterion description	A description of the criterion that is being responded to	BiiDT::Text		
	0..n	Attestation		Main::Attestation		
tir41-089	0..1	Attestation name	The name of the attestation that proves the qualification.	BiiDT::Text		
	0..n	Attestation issuer	The attestation that proves the qualification	BiiDT::Undefined		
tir41-091	0..n	Attached document reference	An internal document reference to an attached document that supports this attestation.	BiiDT::Undefined		
	0..n	Quality insurance	Structured information about the selection criteria for tenderers who are allowed to participate in the tender process, which may be used for automatic evaluation of the administrative qualification documents submitted by the tenderers. These selection criteria regard the requirements mentioned in article 49 of the Directive 2004/18/EC	Main::Quality insurance		
	0..1	Response detail	Further details of the response in a structured form.	Main::Response details		
tir41-092	0..1	Criterion reference	A reference to the criterion that being responded to e.g. the as stated in the Call for tender.	BiiDT::Text		
tir41-093	1..1	Criterion name	The name of the criterion that is being responded to.	BiiDT::Text		
tir41-094	1..1	Criterion description	A description of the criterion that is being responded to	BiiDT::Text		
	0..n	Attestation		Main::Attestation		
tir41-095	0..1	Attestation name	The name of the attestation that proves the qualification.	BiiDT::Text		
tir41-096	0..n	Attestation issuer	The attestation that proves the qualification	BiiDT::Undefined		
	0..n	Attached document reference	An internal document reference to an attached document that supports this attestation.	BiiDT::Undefined		
	0..n	Environmental management	Structured information about the selection criteria for tenderers who are allowed to participate in the tender process, which may be used for automatic evaluation of the administrative qualification documents submitted by the tenderers. These selection criteria regard the requirements mentioned in article 50 of the Directive 2004/18/EC	Main::Environmental management		
	0..1	Response detail	Further details of the response in a structured form.	Main::Response details		
tir41-099	0..1	Criterion reference	A reference to the criterion that being responded to e.g. the as stated in the Call for tender.	BiiDT::Text		
tir41-100	1..1	Criterion name	The name of the criterion that is being responded to.	BiiDT::Text		
tir41-101	1..1	Criterion description	A description of the criterion that is being responded to	BiiDT::Text		
	0..n	Attestation		Main::Attestation		
tir41-102	0..1	Attestation name	The name of the attestation that proves the qualification.	BiiDT::Text		
tir41-103	0..n	Attestation issuer	The attestation that proves the qualification	BiiDT::Undefined		
	0..n	Attached document reference	An internal document reference to an attached document that supports this attestation.	BiiDT::Undefined		
	0..n	Additional documentation	Structured information about the selection criteria for tenderers who are allowed to participate in the tender process, which may be used for	Main::Additional documentation		

InfRqID	Crd	Tree and Business term	Usage	Data Type	ReqID	Note
			automatic evaluation of the administrative qualification documents submitted by the tenderers. These selection criteria regard the requirements mentioned in article 51 of the Directive 2004/18/EC			
	0..1	Response detail	Further details of the response in a structured form.	Main::Response details		
tir41-105	0..1	Criterion reference	A reference to the criterion that being responded to e.g. the as stated in the Call for tender.	BiiDT::Text		
tir41-106	1..1	Criterion name	The name of the criterion that is being responded to.	BiiDT::Text		
tir41-107	1..1	Criterion description	A description of the criterion that is being responded to	BiiDT::Text		
	0..n	Attestation		Main::Attestation		
tir41-108	0..1	Attestation name	The name of the attestation that proves the qualification.	BiiDT::Text		
tir41-109	0..n	Attestation issuer	The attestation that proves the qualification	BiiDT::Undefined		
tir41-110	0..n	Attached document reference	An internal document reference to an attached document that supports this attestation.	BiiDT::Undefined		
	0..n	Classification response	Structured information about the selection criteria for tenderers who are allowed to participate in the tender process, which may be used for automatic evaluation of the administrative qualification documents submitted by the tenderers. These selection criteria regard the requirements mentioned in article 52 of the Directive 2004/18/EC	Main::Classification response		
tir41-111	0..1	Classification code		BiiDT::Undefined		
tir41-112	0..n	List of approved economic operators		BiiDT::Undefined		
	0..1	Response detail	Further details of the response in a structured form.	Main::Response details		
tir41-113	0..1	Criterion reference	A reference to the criterion that being responded to e.g. the as stated in the Call for tender.	BiiDT::Text		
tir41-114	1..1	Criterion name	The name of the criterion that is being responded to.	BiiDT::Text		
tir41-115	1..1	Criterion description	A description of the criterion that is being responded to	BiiDT::Text		
	0..n	Attestation		Main::Attestation		
tir41-116	0..1	Attestation name	The name of the attestation that proves the qualification.	BiiDT::Text		
tir41-117	0..n	Attestation issuer	The attestation that proves the qualification	BiiDT::Undefined		
tir41-118	0..n	Attached document reference	An internal document reference to an attached document that supports this attestation.	BiiDT::Undefined		
	0..n	NaturalPerson	Information about individuals who in one way or the other represent the Economic operator.	Main::NaturalPerson		
tir41-055	1..1	Natural person name	The name of the natural person who will proof suitability with certain criteria.	BiiDT::Text		
tir41-056	0..1	Natural person ID	Identifies the natural person who will proof suitability with certain criteria.	BiiDT::Undefined		
tir41-057	0..1	Natural person role	The role of the natural person.	BiiDT::Undefined		
tir41-065	0..1	Natural person birth place	The natural persons place of birth.	BiiDT::Text		
tir41-066	0..1	Natural person birth date	The natural persons date of birth.	BiiDT::Date		



InfRqID	Crđ	Tree and Business term	Usage	Data Type	ReqID	Note
tir41-064	0..1	└ Natural person registration country	The natural persons country of registration.	BiiDT::Code		
tir41-067	0..1	└ Power of attorney	The power of attorney of this natural person within the company.	BiiDT::Text		
	0..1	└ Postal address	Address information.	CENBII common structures::Postal address		
tir41-058	0..1	└ Address line 1	The main address line in a postal address usually the street name and number.	BiiDT::Undefined		
tir41-059	0..1	└ Address line 2	An additional address line in a postal address that can be used to give further details supplementing the main line. Common use are secondary house number in a complex or in a building.	BiiDT::Undefined		
tir41-060	0..1	└ City	The common name of the city where the postal address is. The name is written in full rather than as a code.	BiiDT::Undefined		
tir41-061	0..1	└ Post code	The identifier for an addressable group of properties according to the relevant national postal service, such as a ZIP code or Post Code.	BiiDT::Undefined		
tir41-062	0..1	└ Region	For specifying a region, county, state, province etc. within a country by using text.	BiiDT::Undefined		
tir41-063	0..1	└ Country code	The country where the address is. The country should always be given by using ISO code 3166 alpha 2	BiiDT::Code		
	0..n	└ Personal situation	Structured information about the exclusion criteria for tenderers who are allowed to participate in the tender process, which may be used for automatic evaluation of the administrative qualification documents submitted by the tenderers. These exclusion criteria regard the requirements mentioned in article 45 of the Directive 2004/18/EC	Main::Personal situation		
	0..1	└ Response detail	Further details of the response in a structured form.	Main::Response details		
tir41-119	0..1	└ Criterion reference	A reference to the criterion that being responded to e.g. the as stated in the Call for tender.	BiiDT::Text		
tir41-120	1..1	└ Criterion name	The name of the criterion that is being responded to.	BiiDT::Text		
tir41-121	1..1	└ Criterion description	A description of the criterion that is being responded to	BiiDT::Text		
	0..n	└ Attestation		Main::Attestation		
tir41-122	0..1	└ Attestation name	The name of the attestation that proves the qualification.	BiiDT::Text		
tir41-123	0..n	└ Attestation issuer	The attestation that proves the qualification	BiiDT::Undefined		
tir41-124	0..n	└ Attached document reference	An internal document reference to an attached document that supports this attestation.	BiiDT::Undefined		
	0..n	└ Professional situation	Structured information about the selection criteria for tenderers who are allowed to participate in the tender process, which may be used for automatic evaluation of the administrative qualification documents submitted by the tenderers. These selection criteria regard the requirements mentioned in article 46 of the Directive 2004/18/EC	Main::Professional situation		
	0..1	└ Response detail	Further details of the response in a structured form.	Main::Response		

InfRqID	Crds	Tree and Business term	Usage	Data Type	ReqID	Note
tir41-125	0..1	Criterion reference	A reference to the criterion that being responded to e.g. the as stated in the Call for tender.	BiiDT::Text		
tir41-126	1..1	Criterion name	The name of the criterion that is being responded to.	BiiDT::Text		
tir41-127	1..1	Criterion description	A description of the criterion that is being responded to	BiiDT::Text		
	0..n	Attestation		Main::Attestation		
tir41-128	0..1	Attestation name	The name of the attestation that proves the qualification.	BiiDT::Text		
tir41-129	0..n	Attestation issuer	The attestation that proves the qualification	BiiDT::Undefined		
tir41-130	0..n	Attached document reference	An internal document reference to an attached document that supports this attestation.	BiiDT::Undefined		
	0..n	Financial capacity	Structured information about the selection criteria for tenderers who are allowed to participate in the tender process, which may be used for automatic evaluation of the administrative qualification documents submitted by the tenderers. These selection criteria regard the requirements mentioned in article 47 of the Directive 2004/18/EC	Main::Financial capacity		
tir41-131	0..1	Amount		BiiDT::Amount		
	0..1	Response detail	Further details of the response in a structured form.	Main::Response details		
tir41-132	0..1	Criterion reference	A reference to the criterion that being responded to e.g. the as stated in the Call for tender.	BiiDT::Text		
tir41-133	1..1	Criterion name	The name of the criterion that is being responded to.	BiiDT::Text		
tir41-134	1..1	Criterion description	A description of the criterion that is being responded to	BiiDT::Text		
	0..n	Attestation		Main::Attestation		
tir41-135	0..1	Attestation name	The name of the attestation that proves the qualification.	BiiDT::Text		
tir41-136	0..n	Attestation issuer	The attestation that proves the qualification	BiiDT::Undefined		
tir41-137	0..n	Attached document reference	An internal document reference to an attached document that supports this attestation.	BiiDT::Undefined		
	0..n	Technical professional capability	Structured information about the selection criteria for tenderers who are allowed to participate in the tender process, which may be used for automatic evaluation of the administrative qualification documents submitted by the tenderers. These selection criteria regard the requirements mentioned in article 48 of the Directive 2004/18/EC	Main::Technical capability		
tir41-138	0..1	Value	The value that complies with the criterion.	BiiDT::Numeric		
	0..1	Period	Dates that describe a period that has relevance in the context of the transaction.	CENBII common structures::Date periods		
tir41-139	1..1	Period start date	The date on which the period starts. The start dates counts as part of the period.	BiiDT::Date		
tir41-140	1..1	Period end date	The date on which the period ends. The end date counts as part of the period.	BiiDT::Date		

InfRqID	Crds	Tree and Business term	Usage	Data Type	ReqID	Note
	0..1	Response detail	Further details of the response in a structured form.	Main::Response details		
tir41-141	0..1	Criterion reference	A reference to the criterion that being responded to e.g. the as stated in the Call for tender.	BiiDT::Text		
tir41-142	1..1	Criterion name	The name of the criterion that is being responded to.	BiiDT::Text		
tir41-143	1..1	Criterion description	A description of the criterion that is being responded to	BiiDT::Text		
	0..n	Attestation		Main::Attestation		
tir41-144	0..1	Attestation name	The name of the attestation that proves the qualification.	BiiDT::Text		
tir41-145	0..n	Attestation issuer	The attestation that proves the qualification	BiiDT::Undefined		
tir41-146	0..n	Attached document reference	An internal document reference to an attached document that supports this attestation.	BiiDT::Undefined		
	0..n	Quality insurance	Structured information about the selection criteria for tenderers who are allowed to participate in the tender process, which may be used for automatic evaluation of the administrative qualification documents submitted by the tenderers. These selection criteria regard the requirements mentioned in article 49 of the Directive 2004/18/EC	Main::Quality insurance		
	0..1	Response detail	Further details of the response in a structured form.	Main::Response details		
tir41-147	0..1	Criterion reference	A reference to the criterion that being responded to e.g. the as stated in the Call for tender.	BiiDT::Text		
tir41-148	1..1	Criterion name	The name of the criterion that is being responded to.	BiiDT::Text		
tir41-149	1..1	Criterion description	A description of the criterion that is being responded to	BiiDT::Text		
	0..n	Attestation		Main::Attestation		
tir41-150	0..1	Attestation name	The name of the attestation that proves the qualification.	BiiDT::Text		
tir41-151	0..n	Attestation issuer	The attestation that proves the qualification	BiiDT::Undefined		
tir41-152	0..n	Attached document reference	An internal document reference to an attached document that supports this attestation.	BiiDT::Undefined		
	0..n	Environmental management	Structured information about the selection criteria for tenderers who are allowed to participate in the tender process, which may be used for automatic evaluation of the administrative qualification documents submitted by the tenderers. These selection criteria regard the requirements mentioned in article 50 of the Directive 2004/18/EC	Main::Environmental management		
	0..1	Response detail	Further details of the response in a structured form.	Main::Response details		
tir41-153	0..1	Criterion reference	A reference to the criterion that being responded to e.g. the as stated in the Call for tender.	BiiDT::Text		
tir41-154	1..1	Criterion name	The name of the criterion that is being responded to.	BiiDT::Text		
tir41-155	1..1	Criterion description	A description of the criterion that is being responded to	BiiDT::Text		
	0..n	Attestation		Main::Attestation		
tir41-156	0..1	Attestation name	The name of the attestation that proves the qualification.	BiiDT::Text		

InfRqID	Crd	Tree and Business term	Usage	Data Type	ReqID	Note
tir41-157	0..n	Attestation issuer	The attestation that proves the qualification	BiiDT::Undefined		
tir41-168	0..n	Attached document reference	An internal document reference to an attached document that supports this attestation.	BiiDT::Undefined		
	0..n	Additional documentation	Structured information about the selection criteria for tenderers who are allowed to participate in the tender process, which may be used for automatic evaluation of the administrative qualification documents submitted by the tenderers. These selection criteria regard the requirements mentioned in article 51 of the Directive 2004/18/EC	Main::Additional documentation		
	0..1	Response detail	Further details of the response in a structured form.	Main::Response details		
tir41-159	0..1	Criterion reference	A reference to the criterion that being responded to e.g. the as stated in the Call for tender.	BiiDT::Text		
tir41-160	1..1	Criterion name	The name of the criterion that is being responded to.	BiiDT::Text		
tir41-170	1..1	Criterion description	A description of the criterion that is being responded to	BiiDT::Text		
	0..n	Attestation		Main::Attestation		
tir41-171	0..1	Attestation name	The name of the attestation that proves the qualification.	BiiDT::Text		
tir41-172	0..n	Attestation issuer	The attestation that proves the qualification	BiiDT::Undefined		
tir41-173	0..n	Attached document reference	An internal document reference to an attached document that supports this attestation.	BiiDT::Undefined		
	0..n	Classification response	Structured information about the selection criteria for tenderers who are allowed to participate in the tender process, which may be used for automatic evaluation of the administrative qualification documents submitted by the tenderers. These selection criteria regard the requirements mentioned in article 52 of the Directive 2004/18/EC	Main::Classification response		
tir41-174	0..1	Classification code		BiiDT::Undefined		
tir41-175	0..n	List of approved economic operators		BiiDT::Undefined		
	0..1	Response detail	Further details of the response in a structured form.	Main::Response details		
tir41-176	0..1	Criterion reference	A reference to the criterion that being responded to e.g. the as stated in the Call for tender.	BiiDT::Text		
tir41-177	1..1	Criterion name	The name of the criterion that is being responded to.	BiiDT::Text		
tir41-178	1..1	Criterion description	A description of the criterion that is being responded to	BiiDT::Text		
	0..n	Attestation		Main::Attestation		
tir41-179	0..1	Attestation name	The name of the attestation that proves the qualification.	BiiDT::Text		
tir41-180	0..n	Attestation issuer	The attestation that proves the qualification	BiiDT::Undefined		
tir41-181	0..n	Attached document reference	An internal document reference to an attached document that supports this attestation.	BiiDT::Undefined		
tir41-009, tir41-097	0..n	Attachment	Attached documents	CENBII common structures:: Attachment		

InfReqID	Crd	Tree and Business term	Usage	Data Type	ReqID	Note
tir41-182	0..1	Attachment ID	A positive identification of the relevant document, such as a unique identifier.	BiiDT::Undefined		
tir41-183	0..1	Attachment description	A short description of the document type.	BiiDT::Text		
tir41-184	0..1	Attached object	The attached document embedded as binary object.	BiiDT::Binary Object		
tir41-008	0..1	Signature		CENBII common structures::Signature		

#### 4.4.1.3 Qualification Submission Transaction Business Rules

##### facts

RuleID	rulenote	target	errorlevel	source	ReqID
BII2-T41-R008	A contracting authority MUST have a contracting authority name or a contracting authority identifier	Contracting Authority	fatal	T41	Tbr41-010
	Economic operator role MUST be one of the following: - Main tenderer - Subcontractor - Consortium leader - Consortium member				

##### Integrity constraints

RuleID	rulenote	target	errorlevel	source	ReqID
BII2-T41-R001	A qualification document MUST have a customization identifier	qualification document	fatal	T41	
BII2-T41-R002	A qualification document MUST have a business process identifier	qualification document	fatal	T41	
BII2-T41-R003	A qualification document MUST have a document identifier	qualification document	fatal	T41	
BII2-T41-R004	A qualification document MUST have a document issue date	qualification document	fatal	T41	Tbr41-026
BII2-T41-R005	A qualification document MUST have a message issue time	qualification document	fatal	T41	Tbr41-026
BII2-T41-R006	A qualification document MUST have a call for tender reference	qualification document	fatal	T41	Tbr41-012

BII2-T41-R007	A qualification document MUST have a contracting authority	qualification document	fatal	T41	Tbr41-010
BII2-T41-R010	A qualification document MUST have at least one economic operator	qualification document	fatal	T41	Tbr41-001
BII2-T41-R011	Each economic operator in a qualification document MUST have an economic operator name	Economic operator	fatal	T41	Tbr41-001
BII2-T41-R013	Each criteria that is being met MUST have a criterion name	qualification document	fatal	T41	Tbr41-016
BII2-T41-R014	Each criteria that is being met MUST have a criterion description	qualification document	fatal	T41	Tbr41-016
BII2-T41-R015	Each natural person MUST have a natural person name	qualification document	fatal	T41	Tbr41-006
	Each economic operator with a subcontractor role MUST have reference to a economic operator				
	There MUST be at least one main tenderer or consortium leader and one or more consortium member				

#### 4.4.2 Qualification Reception Confirmation

Categories	Description and Values
Identifier	BiiTrns042
Description	A structured electronic business document for confirming the reception of a qualification
Partner Types	Customer Supplier
Authorized Roles	Applicant Selector
Legal Implications	By submitting a qualification reception confirmation the Selector confirms that he has received a qualification. The qualification reception confirmation does not imply that the qualification is valid or complete.
Initial Event	Economic Operator as Applicant has sent a Qualification document
Terminal event	Economic Operator as Applicant has received a qualification reception confirmation document.
Scope	All tendering procedures in public or private sector.
Boundary	None specified.

#### 4.4.2.1 Qualification Reception Confirmation Transaction Information Requirements Model

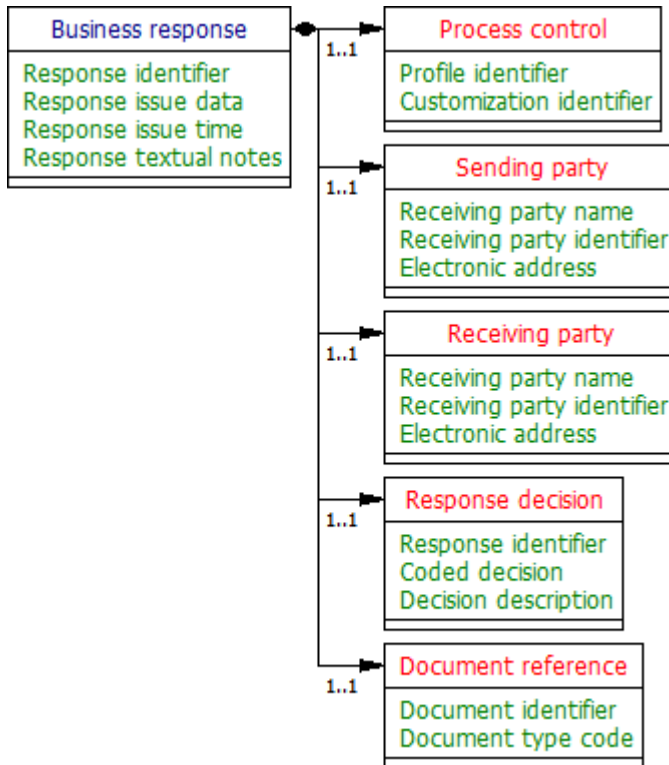



#### 4.4.2.2 Reception Confirmation Transaction Information Requirements

InfRqID	Crđ	Tree and Business term	Usage	Data Type	ReqID	Note
		Business response				
tir42-001	1..1	Response identifier	An transaction instance must contain an identifier. The identifier enables positive referencing the document instance for various purposes including referencing between transactions that are part of the same process.	BiiDT::Undefined		
tir42-002	1..1	Response issue data	The date on which the transaction instance was issued.	BiiDT::Date		
tir42-003	0..1	Response issue time	The time at which the transaction instance was issued.	BiiDT::Time		
tir42-004	0..1	Response textual notes	Used to make any comments or instructions relevant to the response, including the date that the reported decision becomes effective.	BiiDT::Text		
	1..1	Process control	Information about the specification that apply to the transaction.	CENBII common structures::Process control		
tir42-005	1..1	Profile identifier	Identifies the BII profile or business process context in which the transaction appears.	BiiDT::Code	tbr00-001	
tir42-006	1..1	Customization identifier	Identifies the specification of content and rules that apply to the transaction.	BiiDT::Code	tbr00-002	
	1..1	Sending party	The party sending the response.	Main::Party		
tir42-007	0..1	Receiving party name	The name of the party sending the response.	BiiDT::Text		
tir42-008	0..1	Receiving party identifier	It should be possible to specify the identifier or identifiers for the party.	BiiDT::Undefined		
tir42-009	0..1	Electronic address	A response may contain the party electronic address. The address can be of any format and the format should be identified in the message.	BiiDT::Identifier		
	1..1	Receiving party	The party receiving the response.	Main::Party		
tir42-010	0..1	Receiving party name	The name of the party receiving the response.	BiiDT::Text		
tir42-011	0..1	Receiving party identifier	It should be possible to specify the identifier or identifiers for the party.	BiiDT::Undefined		
tir42-012	0..1	Electronic address	A response may contain the party electronic address. The address can be of any format and the format should be identified in the message.	BiiDT::Identifier		
	1..1	Response decision	The business decisions that is reported from the sending party to the receiving party.	Main::Decision		
tir42-013	0..1	Response identifier	Identifies the section (or line) of the document to which the response applies.	BiiDT::Undefined		
tir42-014	0..1	Coded decision	A code for the description of the response to the transaction document. AP= Accepted, RE = Rejected, UN/Cefact 4343 Response type code	BiiDT::Code		
tir42-015	0..1	Decision description	The description of the response to the transaction document.	BiiDT::Text		
	1..1	Document reference	References to the business document that the reported decision applies.	Main::Reference		
tir42-016	0..1	Document identifier	Identifies the document being referred to.	BiiDT::Undefined		
tir42-017	0..1	Document type code	The type of the document being referred to, expressed as a code.	BiiDT::Code		

#### 4.4.2.3 Reception Confirmation Transaction Business Rules

---

## 5 Implementation

The following documents define the binding of the transactions to various syntaxes:

Transaction	Syntax	Binding document
BiiTrns041	UN/CEFACT D11A	BiiTrns41-SB-Cefact.rtf
BiiTrns041	UBL 2.1	BiiTrns41-SB-UBL.rtf

These documents have been annexed to this profile.

Validation tools, such as Schematron files, are available on the BII2 web site: <http://www.cenbii.eu/>

## 6 References

### 6.1 General references relevant for all BII profiles

#### External documents

- UN/CEFACT Modelling Methodology (available at <http://www.untmg.org/specifications/>)
- UML (Unified Modelling Language), version 2.0 (available at <http://www.omg.org/spec/UML/2.0/>)

#### Related publications from CEN/ISSS WS/BII:

- CEN CWA 16073:2010 – BII1 Profiles and deliverables
- CEN CWA xxxx0: BII2 Architecture
- CEN CWA xxxx1, BII2 eNotification profile
- CEN CWA xxxx3, BII2 eCatalogue profiles
- CEN CWA xxxx4, BII2 Post Award profiles

BII2 web site: <http://www.cenbii.eu/>

### 6.2 References specific to this profile

- [1] Directive 2004/18/EC of the European Parliament and of the Council of 31 March 2004 on the coordination of procedures for the award of public works contracts, public supply contracts and public service contracts (*OJ L 134, 30.4.2004, p. 114–240*)
- [2] Directive 2004/17/EC of the European Parliament and of the Council of 31 March 2004 coordinating the procurement procedures of entities operating in the water, energy, transport and postal services sectors (*OJ L 134, 30.4.2004, p. 1–113*)
- [3] Directive 2009/81/EC of the European Parliament and of the Council of 13 July 2009 on the coordination of procedures for the award of certain works contracts, supply contracts and service contracts by contracting authorities or entities in the fields of defence and security, and amending Directives 2004/17/EC and 2004/18/EC (Text with EEA relevance) (*OJ L 216, 20.8.2009, p. 76–136*)
- [4] Commission Implementing Regulation (EU) No 842/2011 of 19 August 2011 establishing standard forms for the publication of notices in the field of public procurement and repealing Regulation (EC) No 1564/2005 Text with EEA relevance (*OJ L 222, 27.8.2011, p. 1–187*)
- [5] Commission Regulation (EC) No 213/2008 of 28 November 2007 amending Regulation (EC) No 2195/2002 of the European Parliament and of the Council on the Common Procurement Vocabulary (CPV) and Directives 2004/17/EC and 2004/18/EC of the European Parliament and of the Council on public procurement procedures, as regards the revision of the CPV
- [6] World Trade Organization, Committee on Government Procurement - Revision of the Agreement on Government Procurement as at 13 December 2010 - Prepared by the Secretariat (GPA/W/313)
- [7] Commission Decision 2008/963/EC – the current list of contracting authorities and entities